

Technical Data

Inlet Filter Silencers, Silencers

Applications & Equipment

- Industrial & Severe Duty
- Blowers - Side Channel & Roots (P.D.)
- Breathers
- Fuel Cells
- Piston Compressors
- Screw Compressors
- Centrifugal Compressors
- Hydraulic Breathers – fine filtration
- Engines
- Fans
- Vacuum Pumps & Systems
- Construction\Contractor Industry
- Medical
- Pneumatic Conveying
- Waste Water Aeration
- Sparging
- Factory Air
- Vacuum Vent Breathers
- Cement Processing
- Power Plants
- Centralized Air Intakes

Identification

Standard Solberg assemblies should have an identification label/nameplate that gives the following information:

- Assembly Model #
- Replacement Element #

The part number designates the filter type, the element configuration and housing connection size. For example, the following part number identifies the filter as being an “FS” design filter with a “275™” element, “P” prefilter and 3” MPT connection size.

FS-275P-300

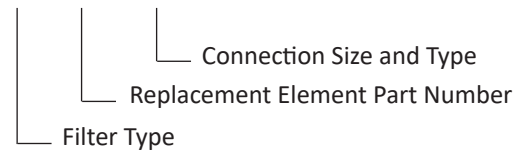

Typical Noise Attenuation

See chart for typical noise attenuation for filter silencers. It may vary due to the wide range of applications, installations, and machines.

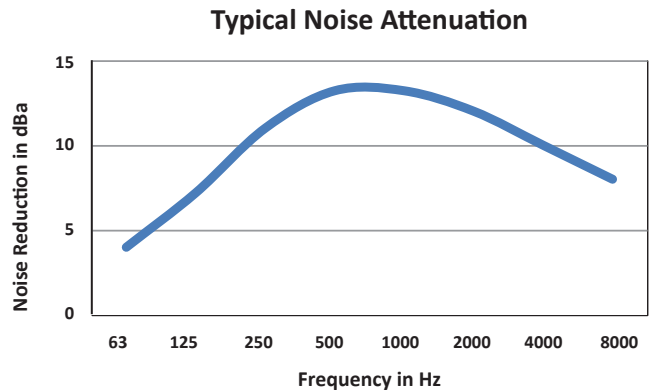

Rev: US0621K

Choosing the Best Filter for Your Equipment

A. When the connection & airflow is known:

1. Select the appropriate connection style. (i.e.: MPT, Flange, NPSC, etc.)
 - a. Verify assembly SCFM (flow) rating. Compare with your required airflow.

(Note: Assembly flow ratings are based on 6,000 FPM or 30m/sec for a given connection size to achieve low pressure drop performance. When required flow exceeds assembly flow rating, the pressure drop through the outlet connection will increase. In such cases select by element SCFM (flow) rating.)

- b. Verify that the flow rating matches connection size; skip to “C. Selecting Elements”.

B. When the connection size is unknown, flexible, or the required flow rating exceeds assembly flow rating:

1. Match required flow rating with the element flow rating.
2. Choose related connection size.

C. Selecting Elements: The filter performance is influenced by the actual application duty and the equipment it is installed on. Regular maintenance checks and proper servicing is required.

Application Duty Descriptions:

Industrial Duty: clean workshop or clean outdoor environment - small element sizing is sufficient.

Severe Duty: dirty workshop, wastewater – medium to large element is recommended.

Extreme Duty: cement, steel making, plastics or dusty material conveying – largest element sizing is recommended.

1. Select media required by your application. Options include:

- a. Standard media
 1. Polyester: all purpose; withstands pulses, moisture, and oily air
 2. Paper: mostly dry, smooth flow applications

- b. Special Media: for a variety of micron levels and media types, see the “Filter Media Specifications” in the Replacement Element Section or contact Solberg.

2. Select element size by matching the element with the anticipated duty and upsize accordingly.

Filter Assembly Maintenance

Request the appropriate maintenance manual for more in-depth information from your Solberg representative or on our website: www.solbergmfg.com.

Element Maintenance

Solberg elements should be replaced once the pressure drop reaches 15-20” H₂O above the initial pressure drop of the installation. Cleaning the element is also an option.

Solberg recommends replacing dirty elements for optimal performance. Any damage which results from by-pass or additional pressure drop created by element cleaning is the sole responsibility of the operator.

Note: The overall performance of a filter element is altered once cleaned. The initial pressure drop after subsequent cleanings will be greater than the original, clean pressure drop of the element. After each cleaning, the pressure drop will continue to increase. Under all circumstances, the initial pressure drop of the element needs to be maintained at less than 15” H₂O.

If the pressure drop exceeds 20” H₂O at start-up; it should be replaced with a new element. With many types of equipment, the maximum pressure drop allowed will be dictated by the ability of the equipment to perform to its rated capacity. Under all circumstances, the operator should avoid exceeding the manufacturer’s recommended maximum pressure drop for their specific equipment.

Rev: US0621K



Discharge Silencer Frames for PD Blowers

BBF Series 2" - 6"

Blower Market Solutions

Maximize Productivity - From junior to experienced technicians, assemble & ship blower packages faster with fewer resources.

Significant Costs Savings - Only one vendor needed to help you improve margins through lower labour and material handling costs.

Engineering Support - Design specifications and drawings are available to help you configure and present your package to your customers.

Ultra Compact Design - Integrated Discharge Silencer offers a low profile and small footprint.

Build Your Sound Enclosure Competitively - The compact design allows you to build significantly smaller and less costly enclosures to meet more stringent noise level requirements.

Benefits

- Compact design for small blower package footprint
- Low profile allows for easier maintenance inspections
- Quick installation time
- Cost savings (minimal packaging, freight & storage)
- Sound enclosures are more economical due to compact frame footprint
- Engineering support provided by Solberg for sizing specifications and specific requirements

Features

- Reactive style silencing design
- Integrated discharge silencer
- Adjustable motor supports for belt tensioning
- Pre-assembled rails to frame
- Corrosive resistant black powder coat carbon steel
- Assembly hardware included



BBF Series frame shown with optional equipment.

Technical Specifications

- Pressure rating: 14.7 PSIG
- Hardware kit included (USA std. nuts, bolts, washers)
- Ports for relief valve, pressure & temperature gauges

Options

- Purpose built belt guard
- Flexible boot kit (clamp, flex adapter)
- Flange adapters
- Snubber discharge silencer for vacuum applications
- Contact factory for best Solberg filter for your package

Rev: US0621K

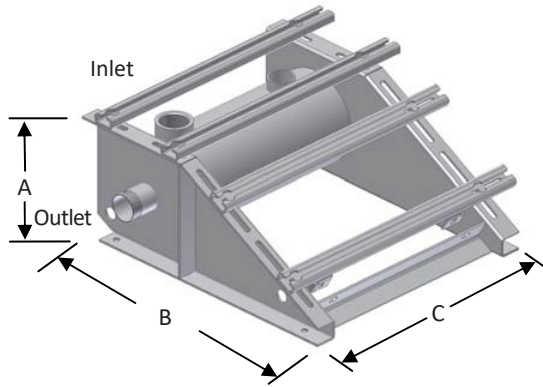

Pipe Stub Inlet	MPT Outlet	Nominal SCFM Rating	Part Number	Dimensions - inches			Relief Valve Port	Suggested HP Range	Approx. Weight lbs.	Belt Guard for BBF Series		Boot Kit Part Number
				A	B	C				Part No.	Approx. lbs.	
2"	2"	135	BBF-200	12	30	26	2 1/2"	5 - 20	130	DL-200	20	BK200
2 1/2"	2 1/2"	195	BBF-250	12	30	26	2 1/2"	5 - 20	130	DL-200	20	BK200
3"	3"	300	BBF-300	15 3/16	35	30 1/2	2"	10 - 50	180	DL-300	23	BK300
4"	4"	520	BBF-400	15 3/16	35	30 1/2	2"	10 - 50	180	DL-300	23	BK400
6"	6" Flg	1100	BBF-600F	17 3/4	39 1/2	37 1/4	3"	20 - 60	398	DL-600	28	BK600

Optional Accessories



Belt guard



Boot kit (includes flexible boot and 2 clamps).

Rev: US0621K

